

Warning

Before carrying out the installation of the D-marc™ 105 system, ensure a thorough risk assessment is implemented by a qualified person and that the area complies with the latest HSE guidelines. During the installation ensure you are following the practices detailed in The Work at Height (Amendment) Regulations 2007.

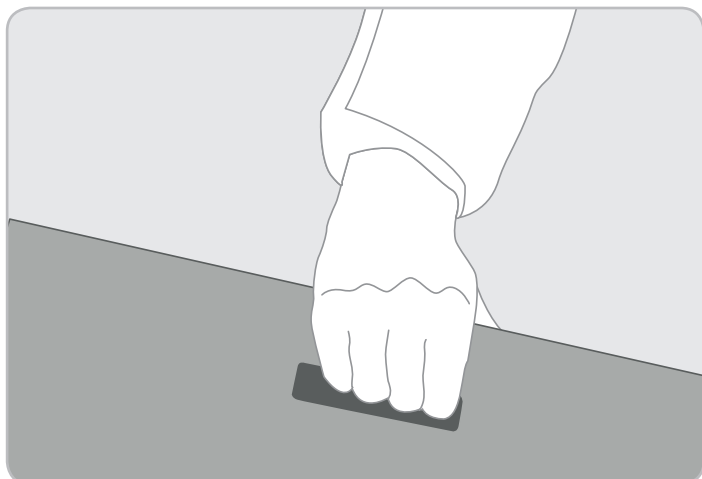

1 The base weights are designed with a carrying handle and weigh less than 12.5 kg each. Refer to the Lifting Operations and Lifting Equipment Regulations 1998 (LOLER) for guidance on safe lifting and be certain to only lift what you are comfortable with.

Tools

Tools required for installation include:

- ▶ Measuring tape
- ▶ Tin snips or similar

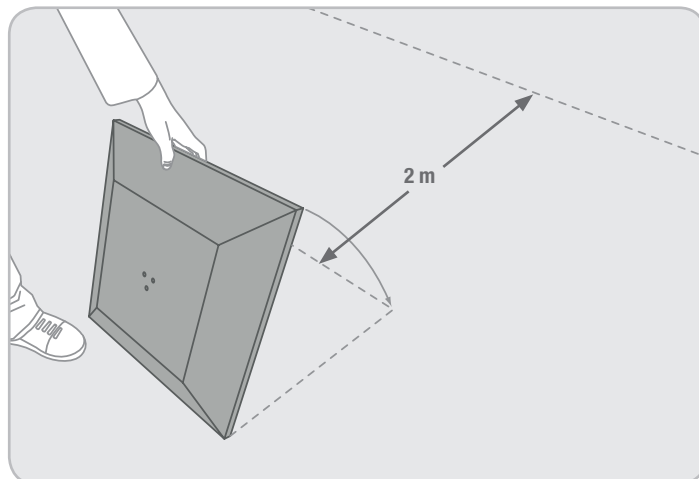

2 Measure 2 m from the hazard whilst being sure to stay at a safe distance from the edge. Remaining within the safe zone, position the first base at this point, placing it down outwards, away from the body as shown, with the D-marc logo facing away from the hazard.

NB: When installing the system onto a single ply roofing membrane, consult the relevant manufacturer for advice.

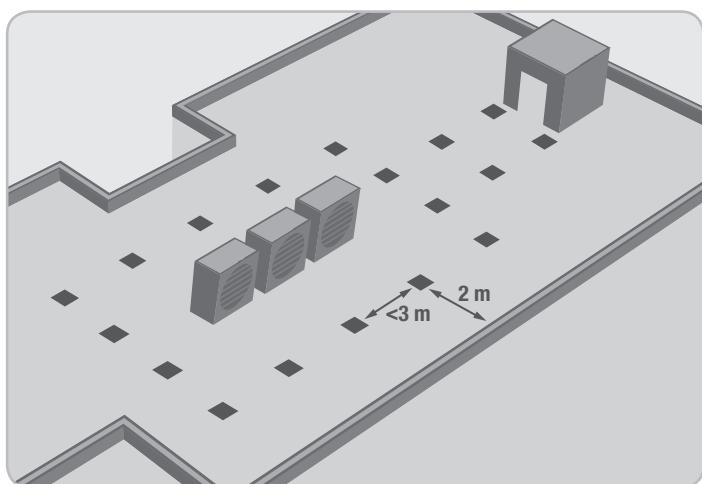

3 Lay the rest of the bases in the same way along the edge of the demarcation zone at regular distances of no more than 3 m apart. Should a corner post be required the bases may be positioned at 90° degrees from each other or even at an acute angle.

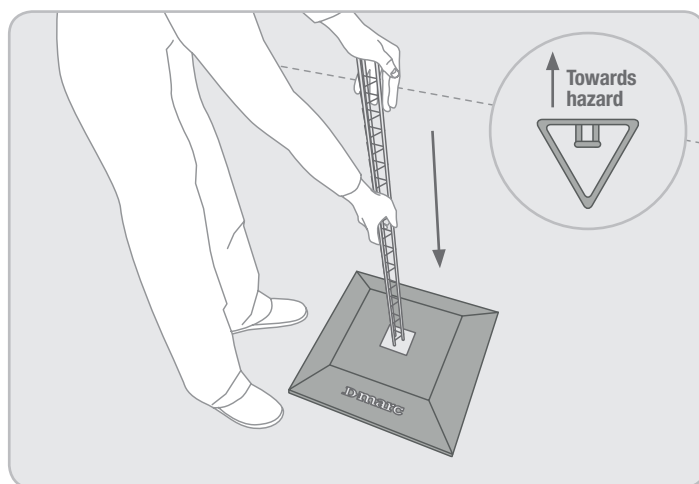

4 Insert the D-marc 105 upright into base ensuring the integrated hook for the chain is on the side facing the hazard. The upright base plate must fit flush into the weighted base.

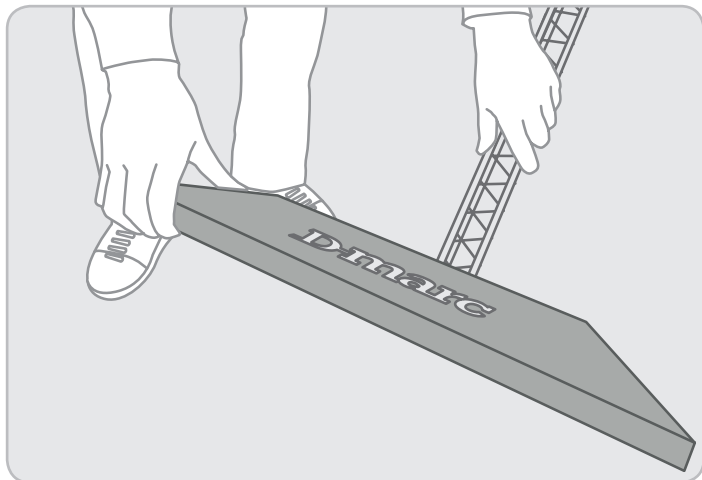

5 Lift the base to reveal the underside.

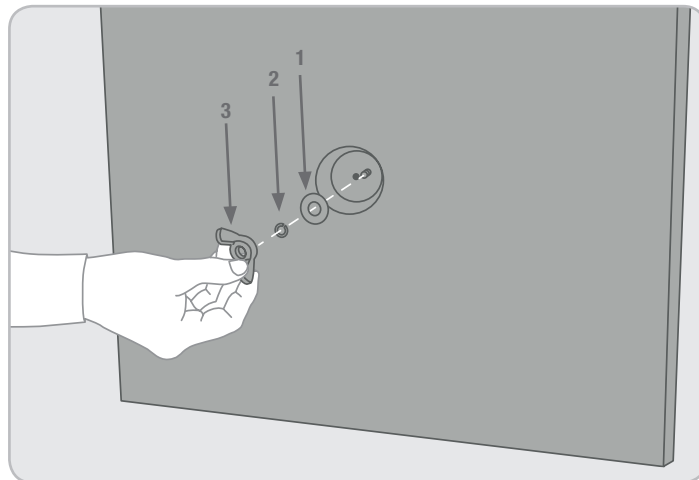

6 First place the repair washer, then the spring washer & finally the wing nut onto the exposed threaded pin & hand tighten until the flat plate on the post fits snugly against the rubber base.

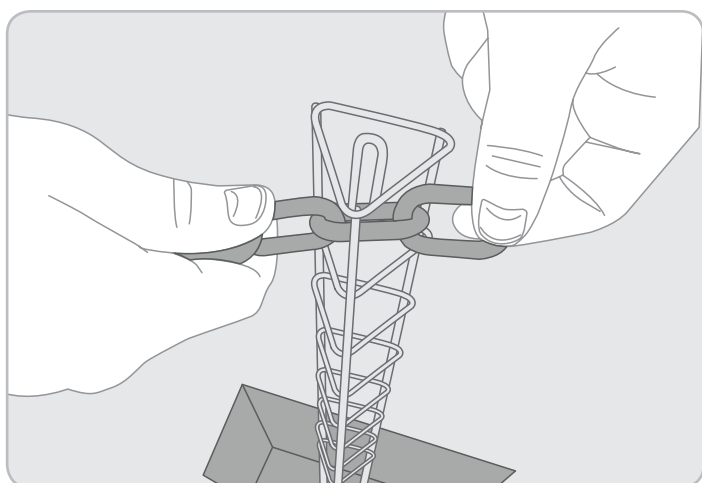

7 Thread the first link on the chain through the top section of the upright and position onto the integrated hook. Continue by feeding the opposing end of the chain through the adjacent upright until the sag in the chain is approximately 100 mm below the horizontal then attach the intermediate link to the hook.

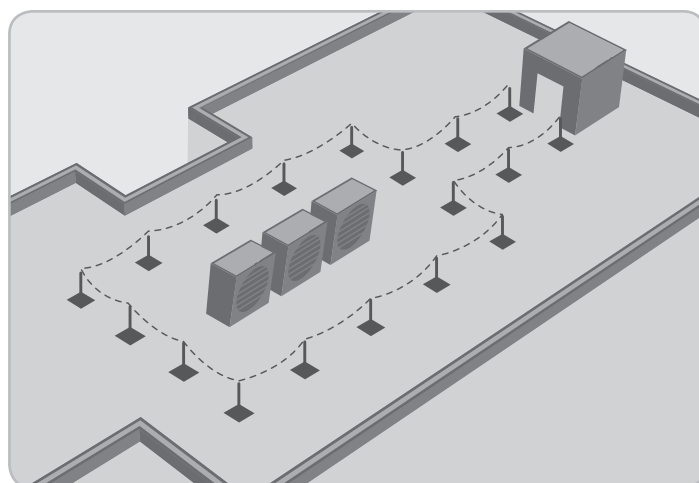

8 Thread the rest of the chain through the D-marc 105 uprights until reaching the final upright, where the remainder of the chain should be trimmed using tin snips. Should multiple lengths of chain be required join each by using the split chain link supplied.